

ICC Evaluation Service, Inc.
www.icc-es.org

Business/Regional Office ■ 5360 Workman Mill Road, Whittier, California 90601 ■ (562) 699-0543
Regional Office ■ 900 Montclair Road, Suite A, Birmingham, Alabama 35213 ■ (205) 599-9800
Regional Office ■ 4051 West Flossmoor Road, Country Club Hills, Illinois 60478 ■ (708) 799-2305

DIVISION: 03—CONCRETE
Section: 03151—Concrete Anchoring

DIVISION: 05—METALS
Section: 05090—Metal Fastening

DIVISION: 06—WOOD AND PLASTICS
Section: 06090—Wood and Plastic Fastening

DIVISION: 09—FINISHES
Section: 09051—Fasteners

REPORT HOLDER:

BLUE POINT FASTENING, INC.
4121 GUARDIAN AVENUE
SIMI VALLEY, CALIFORNIA 93063

EVALUATION SUBJECT:

BLUE POINT POWDER-ACTUATED FASTENERS

1.0 EVALUATION SCOPE

Compliance with the following codes:

- 2006 *International Building Code*® (IBC)
- 2006 *International Residential Code*® (IRC)
- 1997 *Uniform Building Code*™ (UBC)

Properties evaluated:

Structural

2.0 USES

The Blue Point powder-actuated fasteners are used for general fastening of building components to uncracked concrete, including anchorage of wood sill plates; tracks for light-gage steel framing; and supporting hardware for suspended ceiling systems.

3.0 DESCRIPTION

3.1 General:

The fasteners are manufactured from AISI 1060 steel wire, heat-treated to a Rockwell C hardness of 52-55 and mechanically zinc-plated to a minimum thickness of 0.0002 inch (0.005 mm). The zinc plating conforms to ASTM B 695, Class 5, Type 1.

3.2 PD Series Fasteners:

PD Series fasteners have a 0.145-inch-diameter (0.36 mm) shank, and are available in lengths of $\frac{3}{4}$, 1, $1\frac{1}{4}$, $1\frac{1}{2}$, 2, $2\frac{1}{2}$, and 3 inches (19, 25, 32, 38, 51, 64, and 76 mm). The shank has a ballistic point and is fitted with a plastic barrel guide. See Figure 1 of this report.

3.3 PDW Series Fasteners:

PDW Series fasteners consist of the PD Series fastener, described in Section 3.2 of this report, fitted with a 1-inch-diameter (25 mm), No. 16 gage [0.060-inch-thick (1.5 mm)] zinc-plated steel washer having a minimum 0.0002-inch-thick (0.005 mm) plating. See Figure 1 of this report.

3.4 PDAC Series Fasteners:

PDAC Series fasteners consist of the $1\frac{1}{4}$ -inch (32 mm) PD Series fastener, described in Section 3.2 of this report, fitted with a Blue Point Angle Clip. The angle clip measures 1 inch wide (25 mm) by 0.07 inch thick (1.78 mm), and has $\frac{5}{8}$ -inch- and $\frac{7}{16}$ -inch-long (15.9 and 7.9 mm) legs. The angle clips are produced from 0.075-inch-thick (1.9 mm) zinc-plated steel having a minimum 0.0002-inch-thick (0.005 mm) plating. See Figure 1 of this report.

4.0 DESIGN AND INSTALLATION

4.1 Design:

4.1.1 General: The allowable shear and tension (pullout) values in Tables 1 through 4 of this report are for use in allowable stress design, and are for fasteners driven into normal-weight concrete. The stress increases and load reductions described in IBC Section 1605.3, and the stress increases described in UBC Section 1612.3, are not allowed for wind loads acting alone or combined with vertical loads. No adjustment is allowed for vertical loads acting alone. Earthquake load resistance is outside the scope of this report, except as permitted in Section 4.1.3 of this report. Allowable loads for fasteners subjected to combined shear and tension loads are permitted to be calculated by the following equation:

$$\left(\frac{P_s}{P_t}\right) + \left(\frac{V_s}{V_t}\right) \leq 1$$

where:

P_s = Applied service tension load, pounds (N).

P_t = Allowable service tension load, pounds (N).

V_s = Applied service shear load, pounds (N).

V_t = Allowable service shear load, pounds (N).

4.1.2 Wood to Concrete: Lateral design values determined in accordance with Part 11 of the ANSI/AF&PA NDS-05 (IBC) or Part 12 of the ANSI/NFoPA NDS-91 (UBC), as applicable, are permitted with Blue Point fasteners of equal or greater diameters. The wood element is the side member. The fastener bending yield strength shall be the value noted in the NDS-05 or NDS-91, as applicable, based on fastener diameter.

4.1.3 Sill Plate to Foundation Connections:

4.1.3.1 General: Attachment of wood sill plates to the perimeter of concrete shall be allowed under the following conditions:

1. No cold joint exists, between the slab and foundation, below the sill plate.
2. The sill plate is not installed on slabs supported by concrete-block foundation walls.
3. Wood sill plates do not consist of preservative-treated wood.
4. The seismic and wind limitations in Sections 4.1.3.2, 4.1.3.3 and 4.1.3.4 do not apply to fasteners used in interior non-shear-wall applications.

4.1.3.2 IBC: Fasteners used in these sill plate connections provide equivalence to $\frac{1}{2}$ -inch-diameter (12.7 mm) bolts described in IBC Section 2308.6. Usage is limited to Seismic Design Categories A and B, and areas with basic wind speeds (3-second gust) up to 100 mph (161 km/h). The allowable fastener spacings for attachment of wood sill plates to concrete footings or slabs are set forth in Table 3 of this report. For use in 105 mph (169 km/hr) 3-second-gust and greater basic wind speed areas, an engineering analysis, using allowable loads described in Table 1 of this report, is required.

4.1.3.3 IRC: Fasteners used in these sill plate connections provide equivalence to $\frac{1}{2}$ -inch-diameter (12.7 mm) bolts described in IRC Section R403.1.6. Usage is limited to Seismic Design Categories A and B, and areas with basic wind speeds (3-second gust) up to 100 mph (161 km/hr). The allowable fastener spacings for attachment of wood plates to concrete footings or slabs are set forth in Table 3 of this report. For use in 105 mph (169 km/hr) 3-second-gust and greater basic wind speed areas, an engineering analysis, using allowable loads described in Table 1 of this report, is required.

4.1.3.4 UBC: Fasteners used in these sill plate connections provide equivalence to $\frac{1}{2}$ -inch-diameter (12.7 mm) bolts described in UBC Section 1806.6. Usage is limited to Seismic Zones 0, 1, 2 and 3, and areas with basic wind speeds (fastest mile) up to 80 mph (129 km/h). The allowable fastener spacings for attachment of wood plates to concrete footings or slabs are set forth in Table 3 of this report. For use in 90 mph (145 km/h) fastest mile and greater basic wind speed areas, an engineering analysis using allowable loads described in Table 1 of this report, is required.

4.2 Installation:

A low-velocity powder-actuated fastening tool, recommended by Blue Point Fastening, Inc., shall be used to install fasteners into normal-weight concrete. The fastening procedures shall comply with the manufacturer's recommendations. Installation is limited to dry, interior environments. For wood sill plate connections, the PD76S8 fastener, with a minimum $\frac{3}{4}$ -inch-diameter (19 mm), No. 16 gage (0.06-inch-thick), corrosion-resistant washer, or the PDW25-76S8 fastener, as described in Section 3.3 of this report, shall be used. (See also Table 3 of this report.)

5.0 CONDITIONS OF USE

The Blue Point powder-actuated fasteners described in this report comply with or are suitable alternatives to what is specified in, those codes listed in Section 1.0 of this report, subject to the following conditions:

- 5.1** The fasteners are manufactured and identified in accordance with this report.
- 5.2** Fasteners are installed in accordance with this report and Blue Point Fastening, Inc., instructions. In the event of a conflict between this report and the Blue Point Fastening, Inc., instructions, this report governs.
- 5.3** Allowable loads are in accordance with Section 4.1 of this report. Calculations proving that the applied loads are less than the maximum allowable loads described in this report shall be submitted to the building official for approval. The calculations shall be prepared by a registered design professional where required by the statutes of the jurisdiction in which the project is constructed.
- 5.4** Fastener attachment of wood sill plates to foundations complies with Section 4.1.3 of this report. The wood sill plates do not consist of preservative-treated wood.
- 5.5** The minimum concrete thickness is three times the fastener embedment in concrete.
- 5.6** Earthquake load resistance is outside the scope of this report, except as follows:
 - a. As permitted in Section 4.1.3 of this report for wood sill plate applications.
 - b. Fasteners used with architectural, electrical or mechanical components as described in the exceptions to Section 9.6.1 of ASCE/SEI 7 (IBC and IRC).
- 5.7** Use is limited to uncracked concrete. Cracking occurs when $f_t > f_r$ due to service loads or deformations.
- 5.8** Concrete must comply with the applicable code and have a minimum compressive strength of 2,500 psi (17.2 MPa) at the time of fastener installation.
- 5.9** The fasteners are centered in wood sills a minimum of $1\frac{3}{4}$ inches (44 mm) from the concrete edge.

6.0 EVIDENCE SUBMITTED

- 6.1** Data in accordance with the ICC-ES Acceptance Criteria for Fasteners Power-driven into Concrete, Steel and Masonry Elements (AC70), dated October 2006.
- 6.2** A quality control manual.

7.0 IDENTIFICATION

The fasteners shall be labeled with the Blue Point Fastening, Inc., logo, name, address and telephone number; the fastener size, catalog number, head type, and quantity; the evaluation report number (ESR-1530); and the manufacturing date and lot number.

TABLE 1—ALLOWABLE SERVICE TENSION AND SHEAR VALUES FOR BLUEPOINT FASTENERS INSTALLED IN NORMAL-WEIGHT CONCRETE (pounds)^{1,2,3,4,5}

FASTENER	SHANK DIAMETER (inch)	EMBEDMENT DEPTH (inches)	CONCRETE COMPRESSIVE STRENGTH									
			2,500 psi		3,000 psi		3,500 psi		4,000 psi		4,500 psi	
			Tension	Shear	Tension	Shear	Tension	Shear	Tension	Shear	Tension	Shear
PD and PDW Series	0.145	1	121	230	140	230	160	235	180	240	200	245
	0.145	1 ^{3/32}	230	230	215	230	200	235	185	240	175	245

For **SI**: 1 inch = 25.4 mm, 1 psi = 6.89 kPa, 1 lbf = 4.45 N.

¹The fasteners shall not be driven until the concrete has reached the designated minimum compressive strength. Minimum concrete thickness is three times the fastener embedment into the concrete.

²The allowable shear and tension values are for the fastener only. Wood members connected to the fastener shall be investigated separately in accordance with accepted design criteria.

³The stress increases and load reductions described in IBC Section 1605.3, and the stress increases described in UBC Section 1612.3, are not allowed for wind loads acting alone or when combined with vertical loads. No adjustment is allowed for vertical loads acting alone.

⁴The minimum fastener spacing is 4 inches center-to-center, and the minimum edge and end distances are 3 inches.

⁵Earthquake load resistance is outside the scope of this report, except as permitted in Section 4.1.3.

TABLE 2—ALLOWABLE SERVICE TENSION AND OBLIQUE TENSION VALUES FOR BLUE POINT ANGLE CLIP FASTENERS INSTALLED IN NORMAL-WEIGHT CONCRETE (pounds)^{1,2,3,4,5}

FASTENER	SHANK DIAMETER (inch)	EMBEDMENT (inch)	$f'_c = 2500$ psi	
			Vertical Tension	Oblique Tension
PDAC32S8	0.145	1	145	150

For **SI**: 1 inch = 25.4 mm, 1 psi = 6.89 kPa, 1 lbf = 4.45 N.

¹The fasteners shall not be installed until the concrete has reached the designated minimum compressive strength. Minimum concrete thickness is three times the fastener embedment into the concrete.

²The allowable tension values are for the angle clip fastener assembly only. Connected materials shall be investigated separately in accordance with accepted design criteria.

³The stress increases and load reductions described in IBC Section 1605.3, and the stress increases described in UBC Section 1612.3, are not allowed for wind loads acting alone or when combined with vertical loads. No adjustment is allowed for vertical loads acting alone.

⁴Earthquake load resistance is outside the scope of this report.

⁵The oblique tension load is applied at a 45-degree angle; vertical tension load is applied at a 90-degree angle to the substrate (parallel to the fastener).

TABLE 3—SPACING REQUIREMENTS FOR WOOD SILL PLATE ANCHORAGE TO NORMAL-WEIGHT CONCRETE FOOTING OR SLAB

FASTENER ⁷	FASTENER LENGTH (inches)	HEAD DIAMETER (inch)	SHANK DIAMETER (inch)	FASTENER SPACING ^{1,4,6} (ft)		
				Interior Bearing Walls ^{3,5}	Interior Nonbearing Partitions ²	Interior Shear Walls ^{3,5}
PD76S8 or PDW25-76S8	3	0.300	0.145	1.5	3.0	1.5

For **SI**: 1 inch = 25.4 mm, 1 psi = 6.89 kPa, 1 pound per foot = 14.6 N/m.

¹Spacings are based on the attachment of 2-inch nominal thickness wood with specific gravity of 0.5 or greater to concrete floor slabs or footings in accordance with IBC Section 2308.6, IRC Section R403.1.6 (for maximum two-story buildings) or UBC Section 1806.6, as applicable. For other species of lumber, the required spacings of fasteners require special calculations complying with IBC Section 2306 or UBC Chapter 23, Division III, as applicable.

²Walls shall have fasteners placed at 6 inches from ends of sill plates with maximum spacing, as shown in this table.

³Walls shall have two fasteners placed 6 inches and 10 inches, respectively, from each end of sill plates with maximum spacing, as shown in this table.

⁴Fasteners shall not be driven until the concrete has reached a minimum concrete compressive strength of 2,500 psi.

⁵Bearing walls shall have bracing in accordance with IBC Section 2308.9.3, IRC Section R602.10 or UBC Section 2320.11.3, as applicable. Interior and nonbearing partitions are not assumed to be braced.

⁶Fasteners shall not be used to attach shear walls having a unit shear exceeding 100 pounds per foot to other building elements.

⁷The PD76S8 shall be installed with a minimum ³/₄-inch-diameter, No. 16 gage (0.06-inch-thick), corrosion-resistant washer. Fasteners shall be installed a minimum of 1³/₄ inches from concrete edges.

TABLE 4—ALLOWABLE LOADS FOR ATTACHMENT OF STEEL CHANNEL TO NORMAL-WEIGHT CONCRETE FOOTING OR SLAB^{1,2,3,4,5}

FASTENER	SHANK DIAMETER (inch)	EMBEDMENT (inch)	ATTACHED ITEM	CONCRETE COMPRESSIVE STRENGTH, f'_c (psi)	TYPE OF LOAD	ALLOWABLE LOAD (pounds)
PD19S8 and PD25S8	0.145	$\frac{3}{4}$	No. 25 gage steel channel	2,500	Shear	90
	0.145	$\frac{3}{4}$	No. 20 gage steel channel	2,500	Shear	120

For SI: 1 inch = 25.4 mm, 1 foot = 305 m, 1 psi = 6.89 kPa, 1 lbf = 4.45 N.

¹The fasteners shall not be installed until the concrete has reached the designated minimum compressive strength.

²The Nos. 20 and 25 gage steel channels shall have minimum base-metal thicknesses of 0.035 and 0.020 inch, respectively, and be formed from ASTM A 653 SS, Grade 33, steel having a minimum specified yield stress of 33 ksi.

³The stress increases and load reductions described in IBC Section 1605.3, and the stress increases described in UBC Section 1612.3, are not allowed for wind loads acting alone or when combined with vertical loads. No adjustment is allowed for vertical loads acting alone.

⁴Earthquake load resistance is outside the scope of this report.

⁵Minimum fastener spacing and minimum edge distance of fastener to concrete are 4 inches and 3 inches, respectively. Minimum edge distance of fastener to the end of the steel channel is $1\frac{3}{4}$ inches in the loading direction.

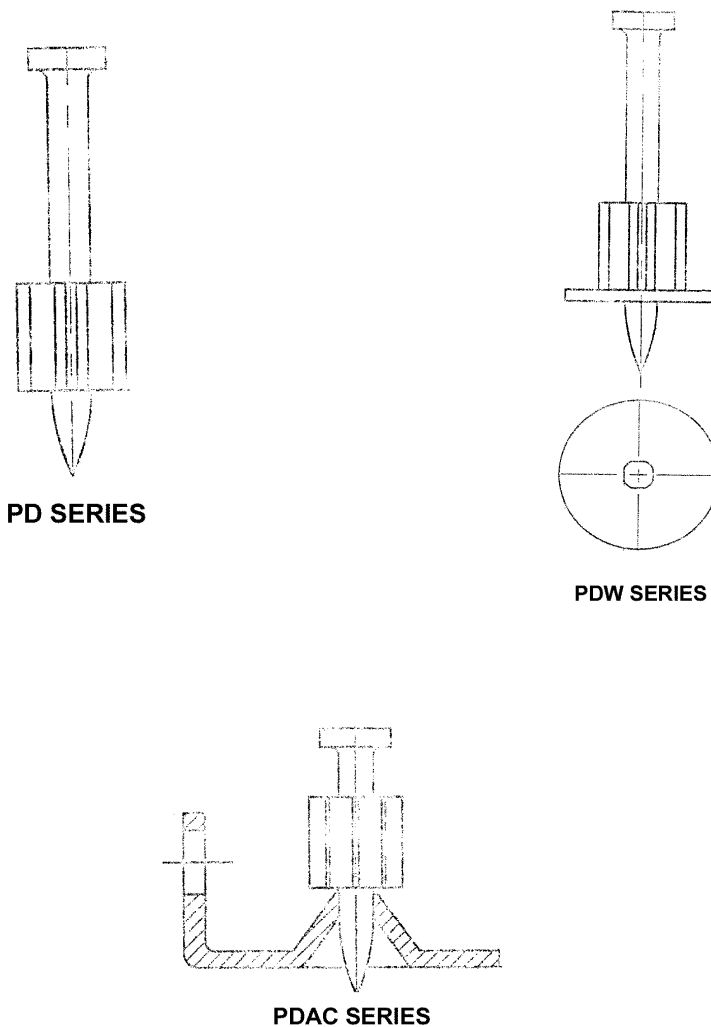

FIGURE 1